

BUNN[®]

trifecta[®]

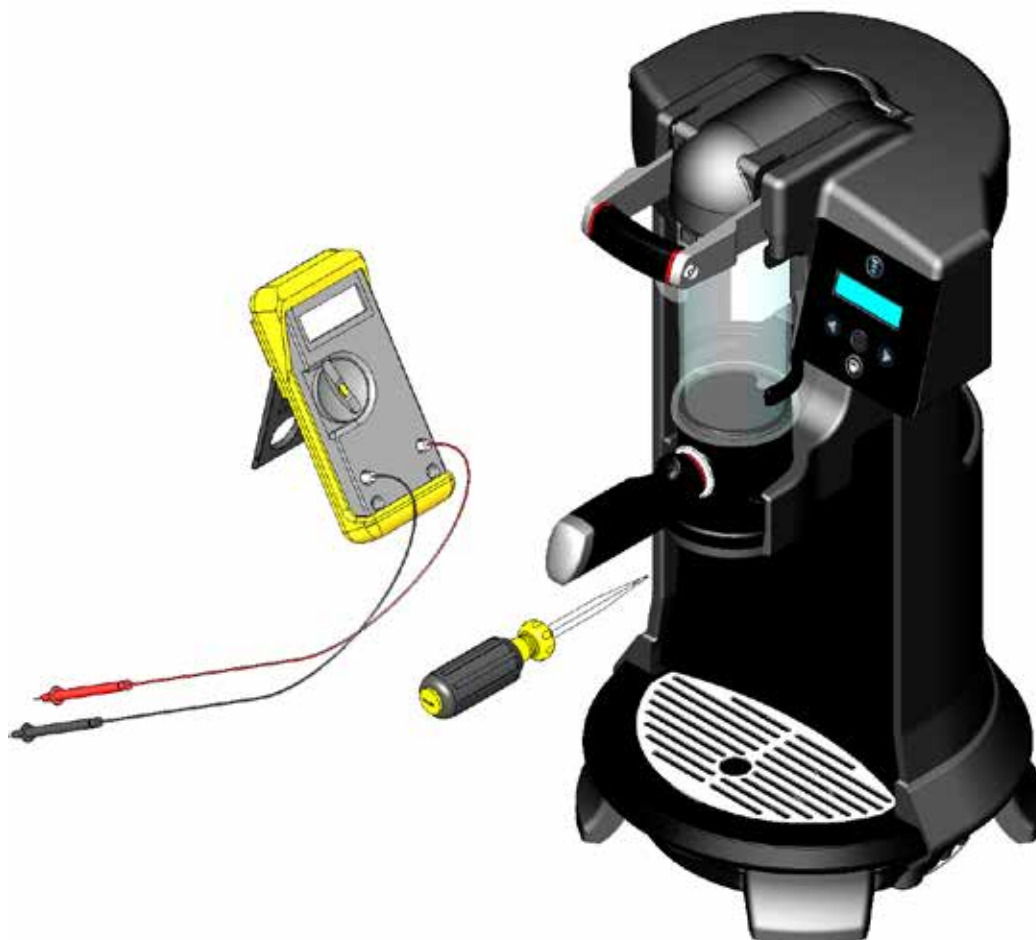

SERVICE & REPAIR MANUAL

BUNN-O-MATIC CORPORATION

POST OFFICE BOX 3227

SPRINGFIELD, ILLINOIS 62708-3227

PHONE: (217) 529-6601 FAX: (217) 529-6644

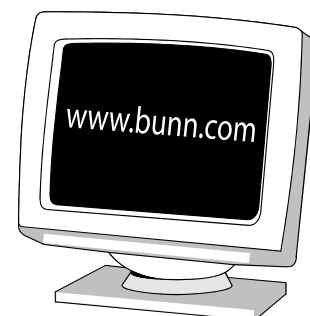

BUNN-O-MATIC COMMERCIAL PRODUCT WARRANTY

Bunn-O-Matic Corp. ("BUNN") warrants equipment manufactured by it as follows:

- 1) Airpots, thermal carafes, decanters, GPR servers, iced tea/coffee dispensers, MCP/MCA pod brewers thermal servers and Thermofresh servers (mechanical and digital)- 1 year parts and 1 year labor.
- 2) All other equipment - 2 years parts and 1 year labor plus added warranties as specified below:
 - a) Electronic circuit and/or control boards - parts and labor for 3 years.
 - b) Compressors on refrigeration equipment - 5 years parts and 1 year labor.
 - c) Grinding burrs on coffee grinding equipment to grind coffee to meet original factory screen sieve analysis - parts and labor for 4 years or 40,000 pounds of coffee, whichever comes first.

These warranty periods run from the date of installation BUNN warrants that the equipment manufactured by it will be commercially free of defects in material and workmanship existing at the time of manufacture and appearing within the applicable warranty period. This warranty does not apply to any equipment, component or part that was not manufactured by BUNN or that, in BUNN's judgment, has been affected by misuse, neglect, alteration, improper installation or operation, improper maintenance or repair, non periodic cleaning and descaling, equipment failures related to poor water quality, damage or casualty. In addition, the warranty does not apply to replacement of items subject to normal use including but not limited to user replaceable parts such as seals and gaskets. This warranty is conditioned on the Buyer 1) giving BUNN prompt notice of any claim to be made under this warranty by telephone at (217) 529-6601 or by writing to Post Office Box 3227, Springfield, Illinois 62708-3227; 2) if requested by BUNN, shipping the defective equipment prepaid to an authorized BUNN service location; and 3) receiving prior authorization from BUNN that the defective equipment is under warranty.

THE FOREGOING WARRANTY IS EXCLUSIVE AND IS IN LIEU OF ANY OTHER WARRANTY, WRITTEN OR ORAL, EXPRESS OR IMPLIED, INCLUDING, BUT NOT LIMITED TO, ANY IMPLIED WARRANTY OF EITHER MERCHANTABILITY OR FITNESS FOR A PARTICULAR PURPOSE. The agents, dealers or employees of BUNN are not authorized to make modifications to this warranty or to make additional warranties that are binding on BUNN. Accordingly, statements by such individuals, whether oral or written, do not constitute warranties and should not be relied upon.

If BUNN determines in its sole discretion that the equipment does not conform to the warranty, BUNN, at its exclusive option while the equipment is under warranty, shall either 1) provide at no charge replacement parts and/or labor (during the applicable parts and labor warranty periods specified above) to repair the defective components, provided that this repair is done by a BUNN Authorized Service Representative; or 2) shall replace the equipment or refund the purchase price for the equipment.

THE BUYER'S REMEDY AGAINST BUNN FOR THE BREACH OF ANY OBLIGATION ARISING OUT OF THE SALE OF THIS EQUIPMENT, WHETHER DERIVED FROM WARRANTY OR OTHERWISE, SHALL BE LIMITED, AT BUNN'S SOLE OPTION AS SPECIFIED HEREIN, TO REPAIR, REPLACEMENT OR REFUND.

In no event shall BUNN be liable for any other damage or loss, including, but not limited to, lost profits, lost sales, loss of use of equipment, claims of Buyer's customers, cost of capital, cost of down time, cost of substitute equipment, facilities or services, or any other special, incidental or consequential damages.

392, AutoPOD, AXIOM, BrewLOGIC, BrewMETER, Brew Better Not Bitter, BrewWISE, BrewWIZARD, BUNN Espresso, BUNN Family Gourmet, BUNN Gourmet, BUNN Pour-O-Matic, BUNN, BUNN with the stylized red line, BUNNlink, Bunn-OMatic, Bunn-O-Matic, BUNNserve, BUNNSERVE with the stylized wrench design, Cool Froth, DBC, Dr. Brew stylized Dr. design, Dual, Easy Pour, EasyClear, EasyGard, FlavorGard, Gourmet Ice, Gourmet Juice, High Intensity, iMIX, Infusion Series, Intellisteam, My Café, Phase Brew, PowerLogic, Quality Beverage Equipment Worldwide, Respect Earth, Respect Earth with the stylized leaf and coffee cherry design, Safety-Fresh, savemycoffee.com, Scale-Pro, Silver Series, Single, Smart Funnel, Smart Hopper, SmartWAVE, Soft Heat, SplashGard, The Mark of Quality in Beverage Equipment Worldwide, ThermoFresh, Titan, trifecta, Velocity Brew, A Partner You Can Count On, Air Brew, Air Infusion, Beverage Bar Creator, Beverage Profit Calculator, Brew better, not bitter., BUNNSource, Coffee At Its Best, Cyclonic Heating System, Daypart, Digital Brewer Control, Nothing Brews Like a BUNN, Pouring Profits, Signature Series, Tea At Its Best, The Horizontal Red Line, Ultra are either trademarks or registered trademarks of Bunn-O-Matic Corporation.

CONTENTS

Warranty	2
Contents.....	3
Component Access	4
Upper Clamp Assembly Removal.....	5
Upper Clamp Assembly Disassembly.....	6
Control Board.....	7
CBA Triac Map	8
Refill/Rinse Valves	10
Air Pump Motors	11
Tank Assembly	12
Limit Thermostat.....	12
Temperature Probe.....	13
Schematic Wiring Diagrams.....	14

COMPONENT ACCESS

This section provides procedures for testing and replacing various major components used in this brewer should service become necessary. Refer to Troubleshooting for assistance in determining the cause of any problem.

WARNING - Inspection, testing, and repair of electrical equipment should be performed only by qualified service personnel. The brewer should be unplugged when servicing, except when electrical tests are required and the test procedure specifically states to plug in the brewer.

WARNING - Disconnect the brewer from the power source before the removal of any panel or the replacement of any component.

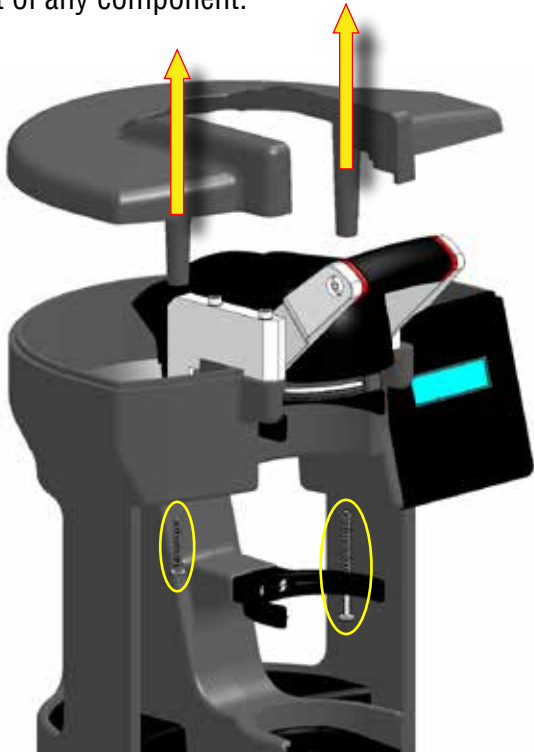

FIG. 10-1 Remove 2 screws from underneath, lift top cover to remove.

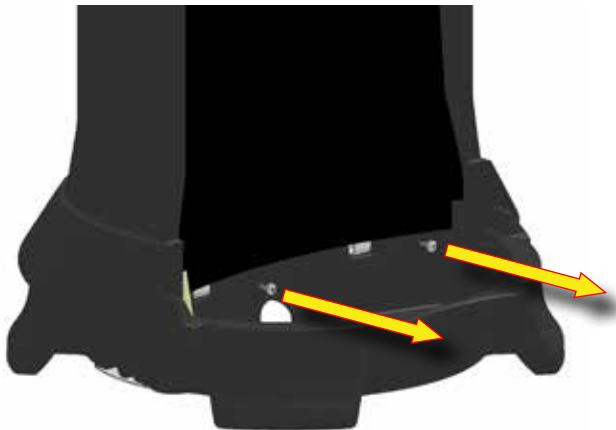

FIG. 10-2 Front panel. Remove 2 screws.

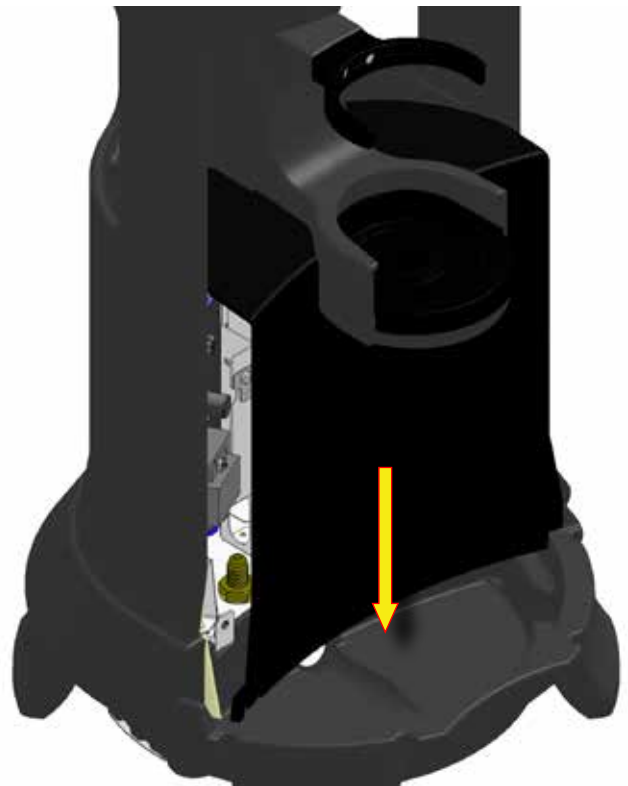

FIG. 10-3 Push front panel down.

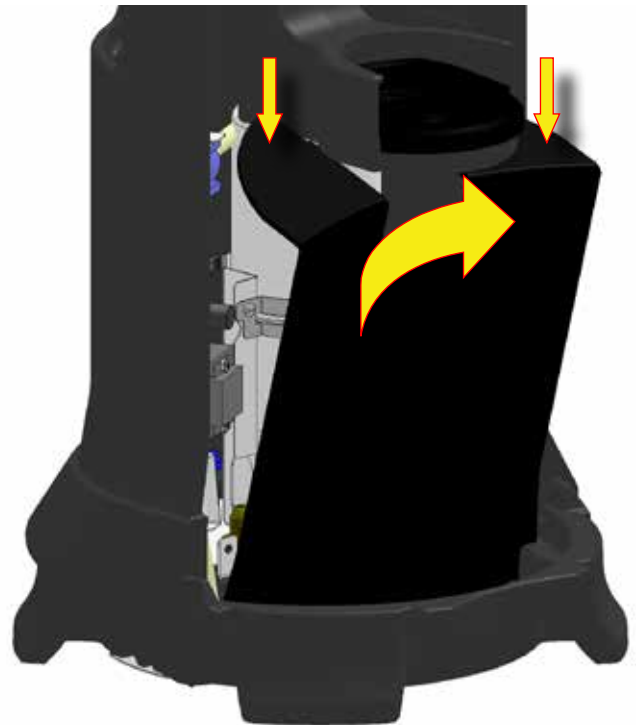

FIG. 10-4 Pull top of panel towards you while pushing down on the side flaps.

UPPER CLAMP ASSEMBLY REMOVAL

WARNING - Disconnect the brewer from the power source before the removal of any panel or the replacement of any component.

1. Remove top cover.
2. Using 5/32" Allen wrench, remove 4 socket head screws. FIG 5-1

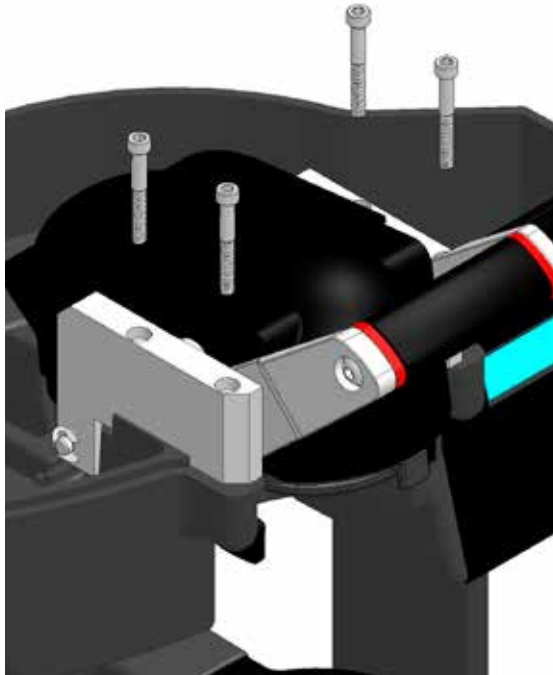

FIG. 5-1

3. Disconnect braided hose from Tee fitting. FIG 5-2

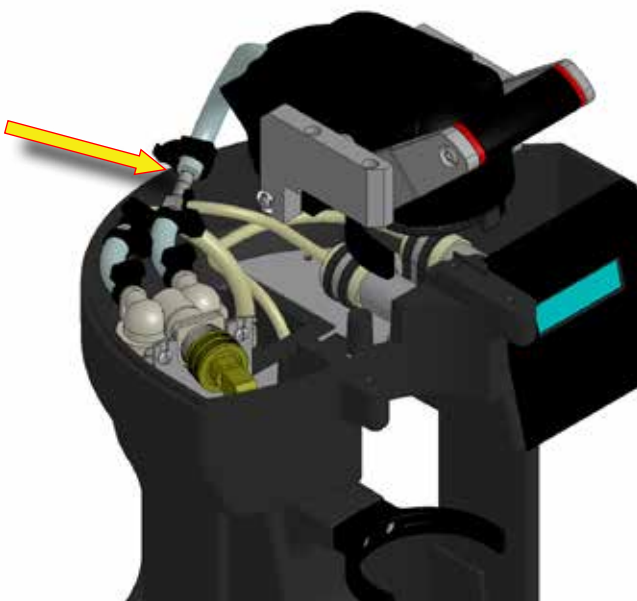

FIG. 5-2

4. Remove front panel.
5. Disconnect silicon hose from vent valve. Disconnect 2 pin white/violet harness from Control Board J-11. FIG 5-3

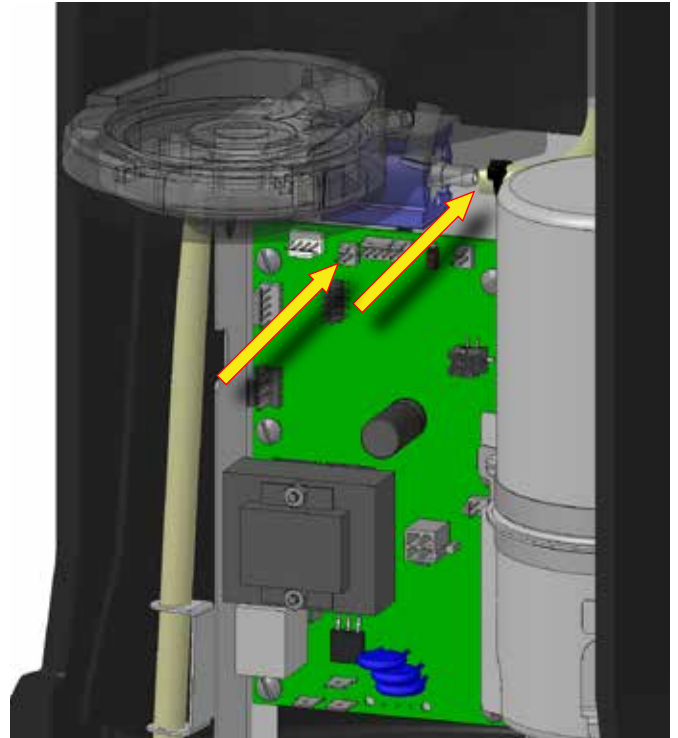

FIG. 5-3

6. Lift sprayhead assembly from brewer chassis.

UPPER CLAMP ASSEMBLY DISASSEMBLY

WARNING - Disconnect the brewer from the power source before the removal of any panel or the replacement of any component.

1. Remove c-clip, pivot shaft and brew chamber lifter.

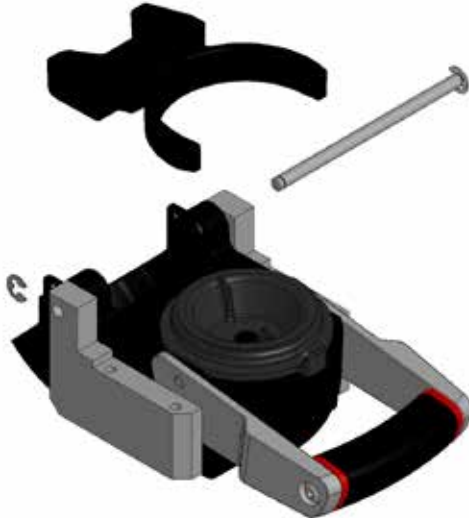

FIG. 6-1

2. Using 5/32" Allen wrench, remove one or both socket head screws from handle. Split the slide mount brackets from sprayhead assembly as shown. FIG 6-2



FIG. 6-2

3. Lift the sprayhead plug assembly out of the cap.

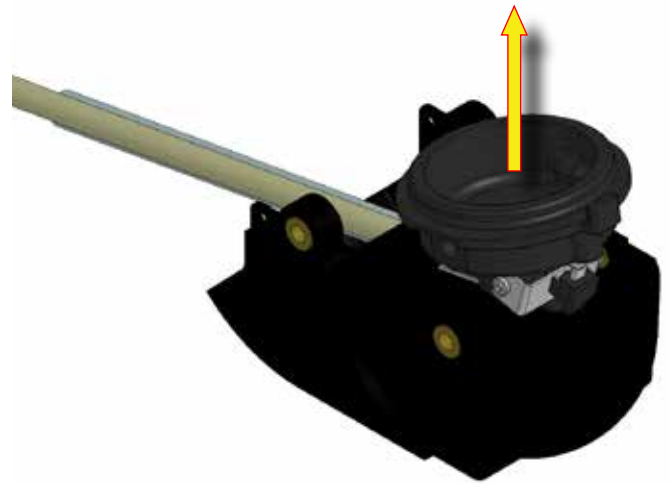

FIG. 6-3

SAFETY SWITCH REPLACEMENT

NOTE: Testing the switch should be done in Program mode "TEST SWITCHES"

4. Place the assembly as shown (so the switch actuator pin does not fall out). Remove the 2 phillips screws securing the switch bracket. NOTE: If replacing the switch harness, secure it to the unused hose barb to prevent damage to wires.



FIG. 6-4

REASSEMBLY

5. During reassembly, be sure to lubricate o-rings, bushings and guides as required.

CONTROL BOARD

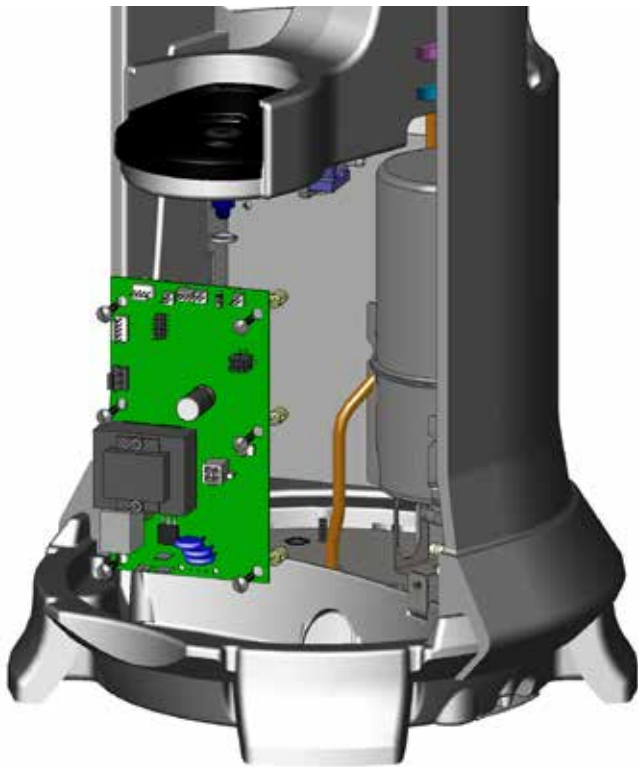

FIG. 11-1 CONTROL BOARD

Location:

The Control Board is located behind the front cover.

Test Procedures:

The test procedures for the control board will vary depending upon the problems experienced by the brewer. Refer to the Troubleshooting section which is divided into three sections, Refill Circuit, Heating Circuit, and Brewing Circuit.

Check for Power to board:

1. Place one meter lead at L1 terminal and the other lead at L2 terminal on the Control Board.
2. With the power connected to brewer, the voltage reading to the board should be the line voltage rated for that model.

If no voltage is present, check power cord to the board. If voltage is present, and brewer does not power on replace Control Board

Removal and Replacement:

1. Disconnect brewer from power source.
2. Disconnect the wires and harnesses from the control board.
3. Remove the six screws securing the control board to the bracket.
4. Secure the new control board to the bracket with six screws.
5. Re-connect wires and harnesses.

CONTROL BOARD TRIAC MAP

Triac: Load Component: Connector:

- | | | |
|-----|-----------------|-----------------------------|
| TH1 | Tank Heaters | Heater Terminal/L2 Terminal |
| TH2 | Refill solenoid | Red wire/White wire |
| TH3 | Rinse solenoid | Brown wire/White wire |

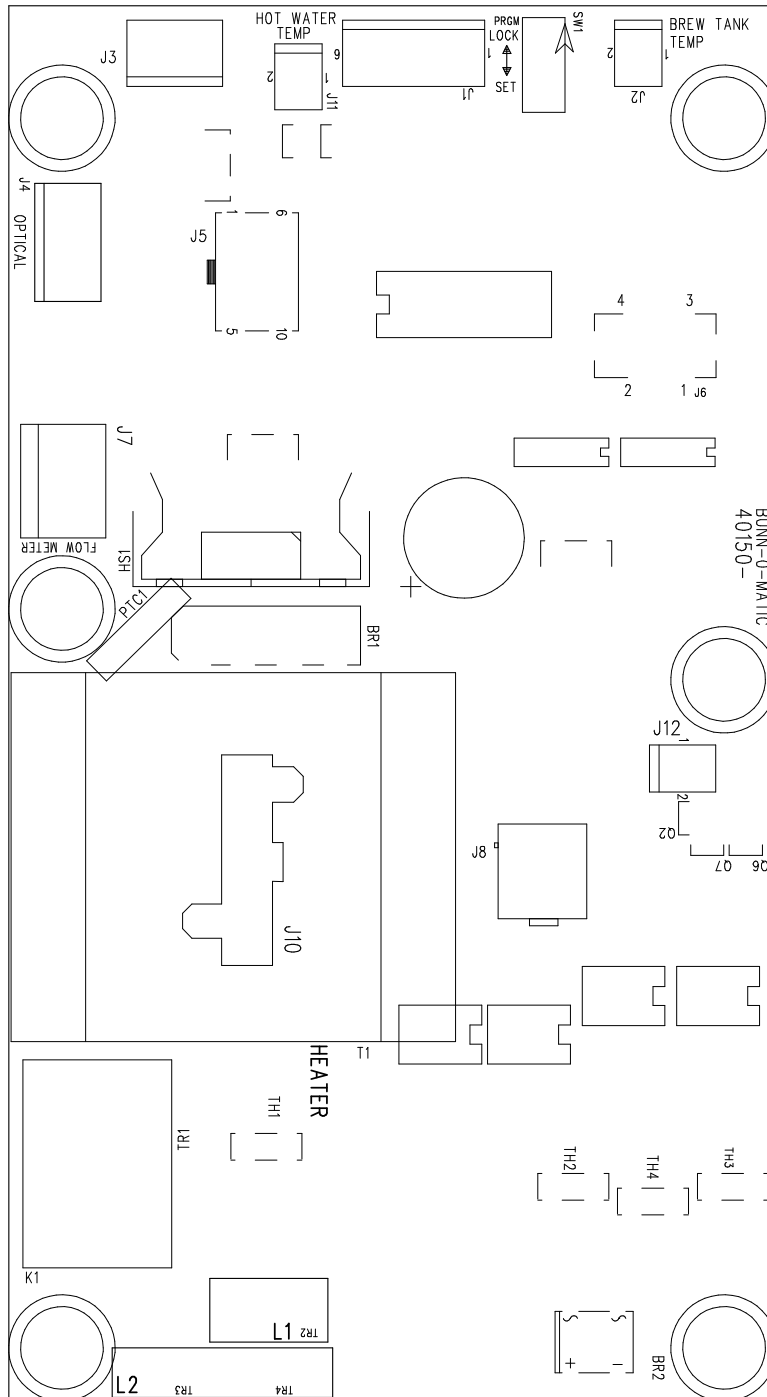

FIG. 12-1 TRIAC MAP

DISPLAY/SWITCH BOARD

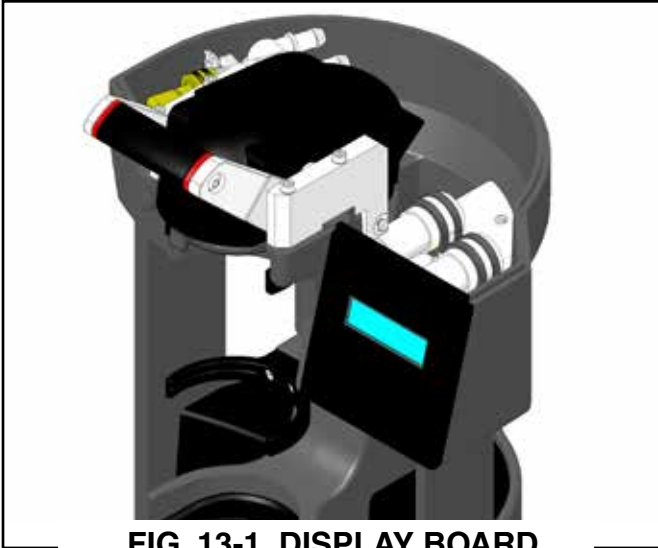

FIG. 13-1 DISPLAY BOARD

Location:

The display board is located on the front face plate.

Test Procedures:

Check for 12VDC supply to display. Place meter leads at green and black wires as shown below.

Test Switches Procedure:

Enter program mode by pressing both arrow buttons until display reads "RECIPE CHANGES". Press and release the center program button until display reads "SERVICE TOOLS". Select "YES". Display will read "TEST OUTPUTS", select "NO". Display will read "TEST SWITCHES", select "YES". Display will read "PRESS PROGRAM TO EXIT" as it enters the test mode. When no switches are activated, the display will read "NOTHING PRESSED". You can press any of the buttons on the control panel and display will indicate which one you activated. You can also test the safety switch by opening and closing the brew chamber handle. Press program button to go back to previous screen.

Removal and Replacement:

1. Disconnect brewer from power source.
2. Remove top cover.
3. Lift board/bezel assembly up.
4. Disconnect harness from board.
5. Remove 4 screws securing board to bezel.
6. Install new board w/keys to bezel.
7. Connect harness to board.
8. Install board/bezel assembly back into housing.
9. Install top cover.

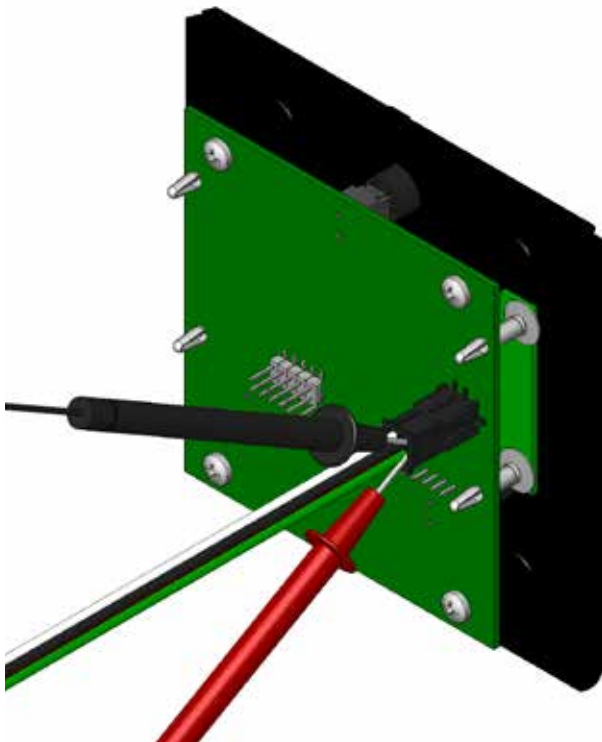

FIG. 13-2 DISPLAY BOARD TEST



Wrap a thin paper clip around each meter lead and extend past the tip by $\frac{1}{4}$ " - $\frac{1}{2}$ ". You may need to sand off the clear coating on some clips!

REFILL/RINSE SOLENOID VALVES

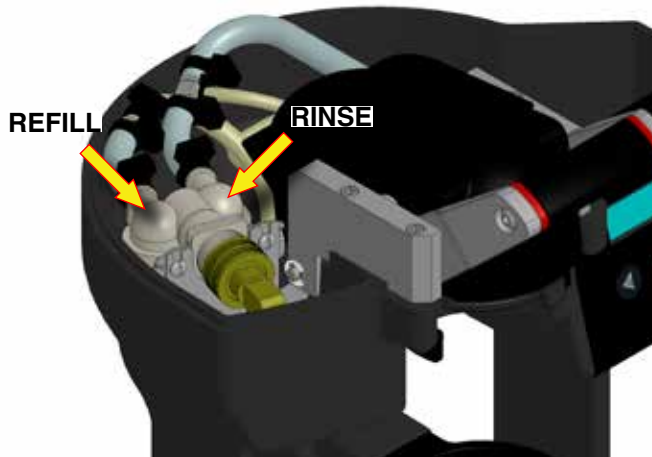

FIG. 14-1 REFILL/RINSE SOLENOID

Location:

The brew valve is located inside the top cover.

Test Procedures:

1. Refer to the Programming Section for Service Tools/ Test Outputs/Refill/Rinse Valve.
2. Be sure brew chamber/cup & container are in place before activating either valve.
3. Check the valve for coil action. Turn on the valve in the test mode. Listen carefully in the vicinity of the solenoid for a click as the coil pulls the plunger in.
If no sound is heard, proceed to #4.
If the sound is heard as described, there may be a blockage in the valve, hose, tank, or sprayhead. Disconnect the brewer from the power source. Remove the valve and inspect for blockage, and de-lime all related areas.
4. Connect the voltmeter leads to the coil terminals. Turn on the valve with the test mode. The indication will be the rated line voltage.

If voltage is present as described, but no coil action is observed, check continuity (resistance) of coils (.96k Ω ±10% for 100V models [gray], 1.2k Ω ±10% for 110-120V models [black], 4.23k Ω ±10% for 220-240V models [white]). If either coil does not have the resistance listed above, solenoid is defective. Replace solenoid and test again to verify repair.

If voltage is not present as described, refer to Wiring Diagrams and check the brewer wiring harness. Also check the control board and switches for proper operation.

Removal and Replacement:

1. Disconnect the brewer from water & power sources.
2. Unscrew the brass elbow assembly from the valve.
3. Loosen (do not remove) the (2) M4 X 6mm screws securing the solenoid to the bracket.
4. Slide the solenoid up & out of bracket.
5. Remove hoses from the valve.
6. Disconnect wires from the valve.
7. Install new valve in reverse order.

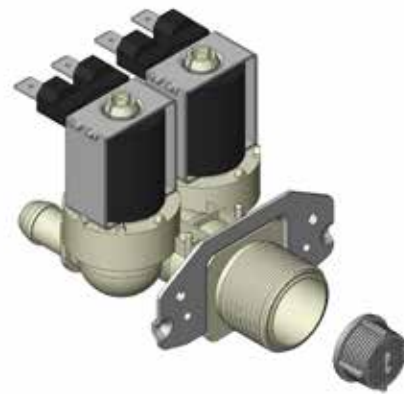

FIG. 14-2 EXPLODED VIEW

NOTE:

Do not use similar valves from other models, as this one has a flow control built into the inlet of the refill side.

AIR PUMP MOTORS

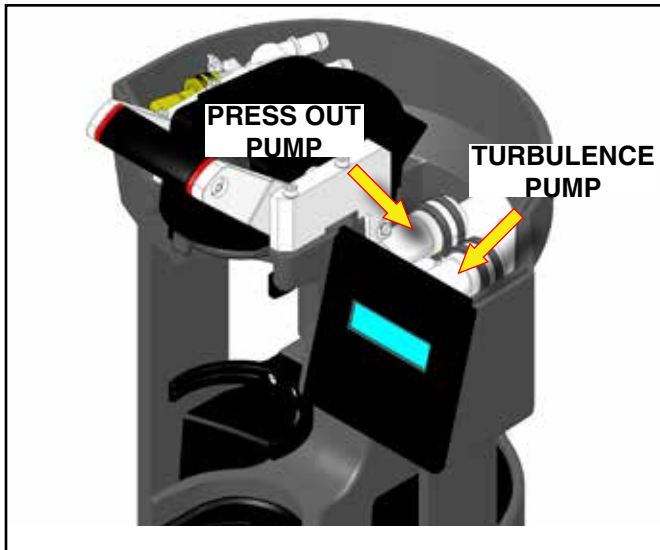

FIG. 15-1 PUMP MOTORS

Location:

The pump motors are located inside the top cover.

Test Procedures:

1. Refer to the Programming Section for Service Tools/ Test Outputs/Turbulence/Press Out Pumps.
2. Be sure brew chamber/cup & container are in place before activating either motor.
3. Turn on the motor with the test mode. Listen carefully in the vicinity of the motor to hear if it's running. *If no sound is heard as described, proceed to #4. If the sound is heard as described, there may be a blockage in the hoses. Disconnect the brewer from the power source. Remove the hoses and inspect for blockage.*
4. Connect the voltmeter leads to the coil terminals. Turn on the valve with the test mode. The indication will be 0VDC off, 12-18VDC on.

If voltage is present as described, but no coil action is observed, valve is defective. Replace valve and test again to verify repair. If voltage is present as described, but no action is observed, check continuity (resistance) of coils 20-30 Ω . If coil does not have the resistance listed above, pump is defective. Replace pump and test again to verify repair.

If voltage is not present as described, refer to Wiring Diagrams and check the brewer wiring harness. Also check the control board and switches for proper operation.

Removal and Replacement:

1. Disconnect the brewer from the power source.
2. Remove nut and clamp.
3. Disconnect harness and hose from the pump.
4. Install new pump in reverse order.



FIG. 15-2 PUMP MOTOR

TANK ASSEMBLY

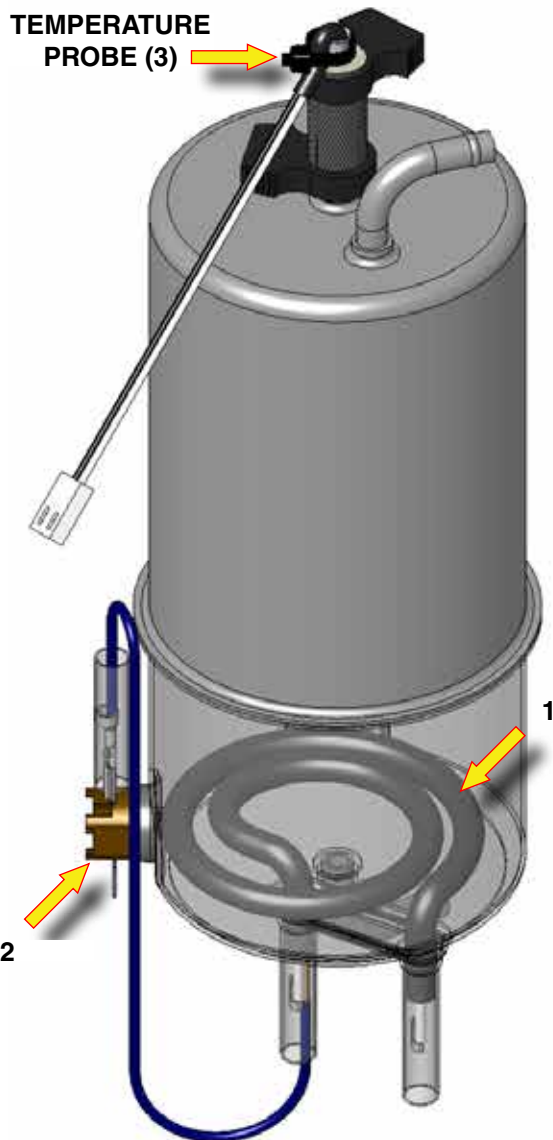

FIG. 16-1 TANK HEATER (1)

Location:

The tank heaters are located inside the tank and secured to the tank bottom.

Test Procedures:

1. With a voltmeter, check voltage across the white wire (120V Models) or red wire (120/208-240V Models) from the terminal block and black wire from the control board. Connect brewer to the power source. The indication will be the rated line voltage (during a heating cycle).
2. Disconnect the brewer from the power source.

If voltage is present as described, proceed to #3.

If voltage is not present as described, refer to the Wiring Diagrams and check wiring harness.

HEATER	RESISTANCE
1450W-100V	8.9-10.9 Ω
1450W-120V	32.8-40.1 Ω
1450W-230V	6.2- 7.6 Ω
TERMINAL TO SHEATH - INFINITE (OPEN)	

3. Disconnect the wires from the tank heater terminals.
4. Check resistance value across tank heater terminals and compare to chart.

If resistance is present as described, reconnect the wires, the tank heater is ok.

If resistance is not present as described, replace the tank assembly.

Removal and Replacement:

1. Remove the front access panel.
2. Drain water from the tank.
3. Disconnect all the hoses from the tank.
4. Disconnect all the wires from the tank.
5. Remove the 2 screws and strap securing the tank.
6. Install new tank assembly in reverse order.

VIDEO CLIP: Tank removal *Click - >*



FIG. 21-1 LIMIT THERMOSTAT (2)

NOTE: One additional limit thermostat used on 230V models.

Test Procedures:

1. Disconnect the brewer from the power source.
2. Disconnect the wires from the limit thermostat.
3. With an ohmmeter, check for continuity across the limit thermostat terminals.

If continuity is present as described, the limit thermostat is operating properly.

If continuity is not present as described, replace the limit thermostat.

Removal and Replacement:

1. Remove the wires from limit thermostat.
2. Carefully slide the limit thermostat out from under the retaining clip and remove limit thermostat.
3. Carefully slide the new limit thermostat into the retaining clip. Ensure the metal face has good contact with tank.

TANK ASSEMBLY

TEMPERATURE PROBE (3)

Location:

The temperature probe is inserted through the tank lid assembly.

Test Procedures:

1. Disconnect the brewer from the power source.
2. With a DC voltmeter, check voltage across the two wires at J2 on control board (black probe to black wire, red probe to white wire refer to FIG 17-1). Connect the brewer to the power source. The indication should be between 4.5vdc (cool) to 1vdc at ready temperature.
3. Disconnect the brewer from the power source.

If voltage is present as described, circuit is working correctly.

If voltage is not present as described, proceed to #4.

4. Disconnect temperature probe from J2 on control board. Check the resistance across the two terminals of the temperature probe. The indication should be between 10.5K Ω cool to 870 Ω at ready temperature.

If resistance is to specification, replace the control board.

If resistance is not to specification, replace the temperature probe.

Removal and Replacement:

1. Disconnect the brewer from the power source.
2. Disconnect the two pin connector from J2 on control board.
3. Remove clamp. Pull probe out of tubing.
4. Install in reverse order.

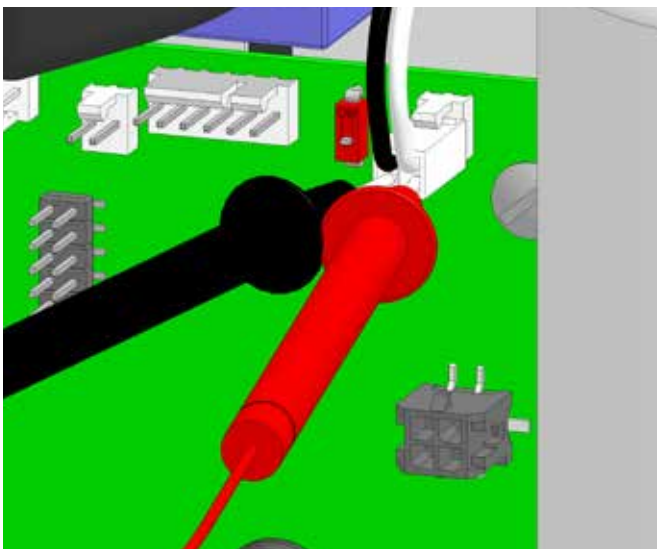
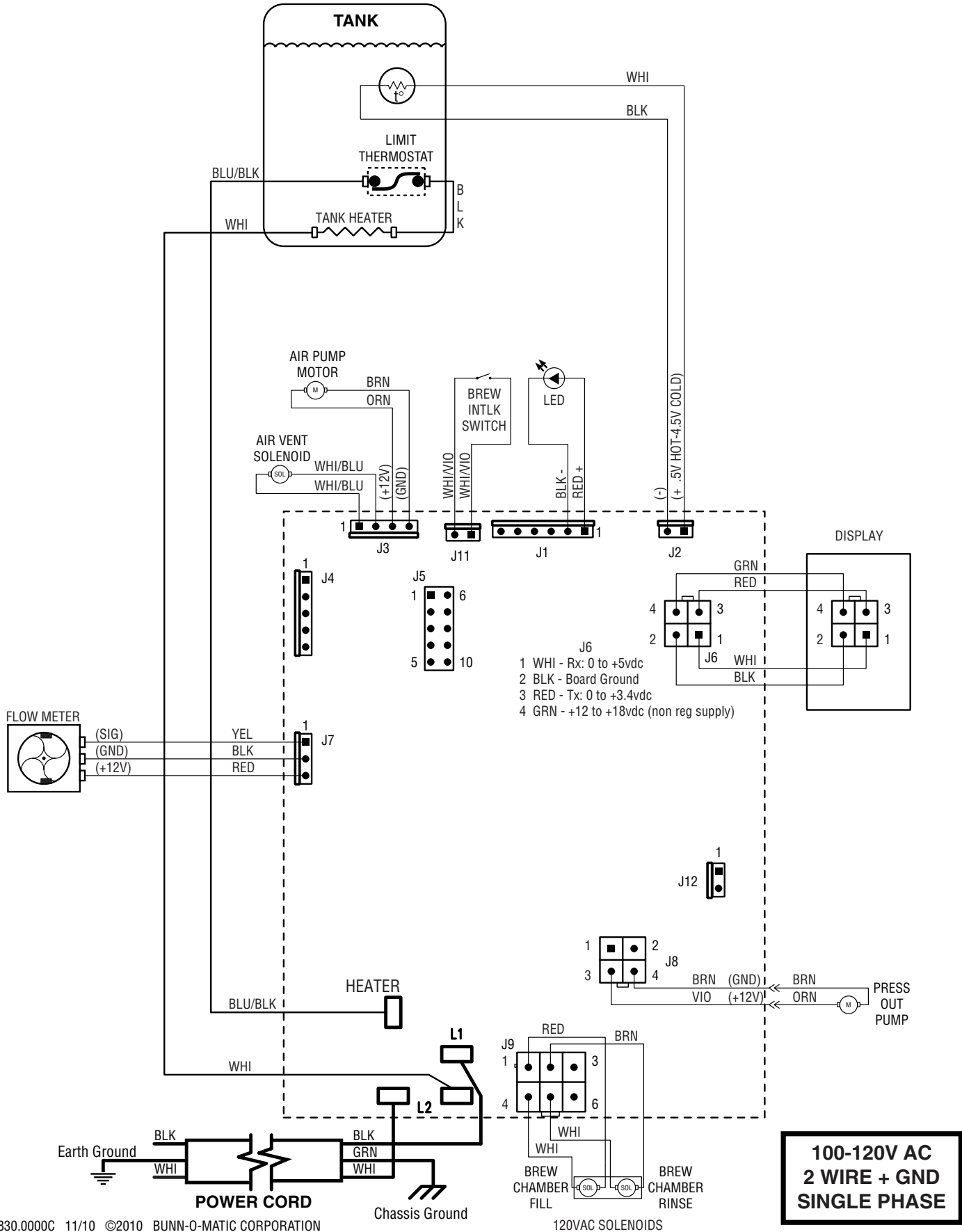
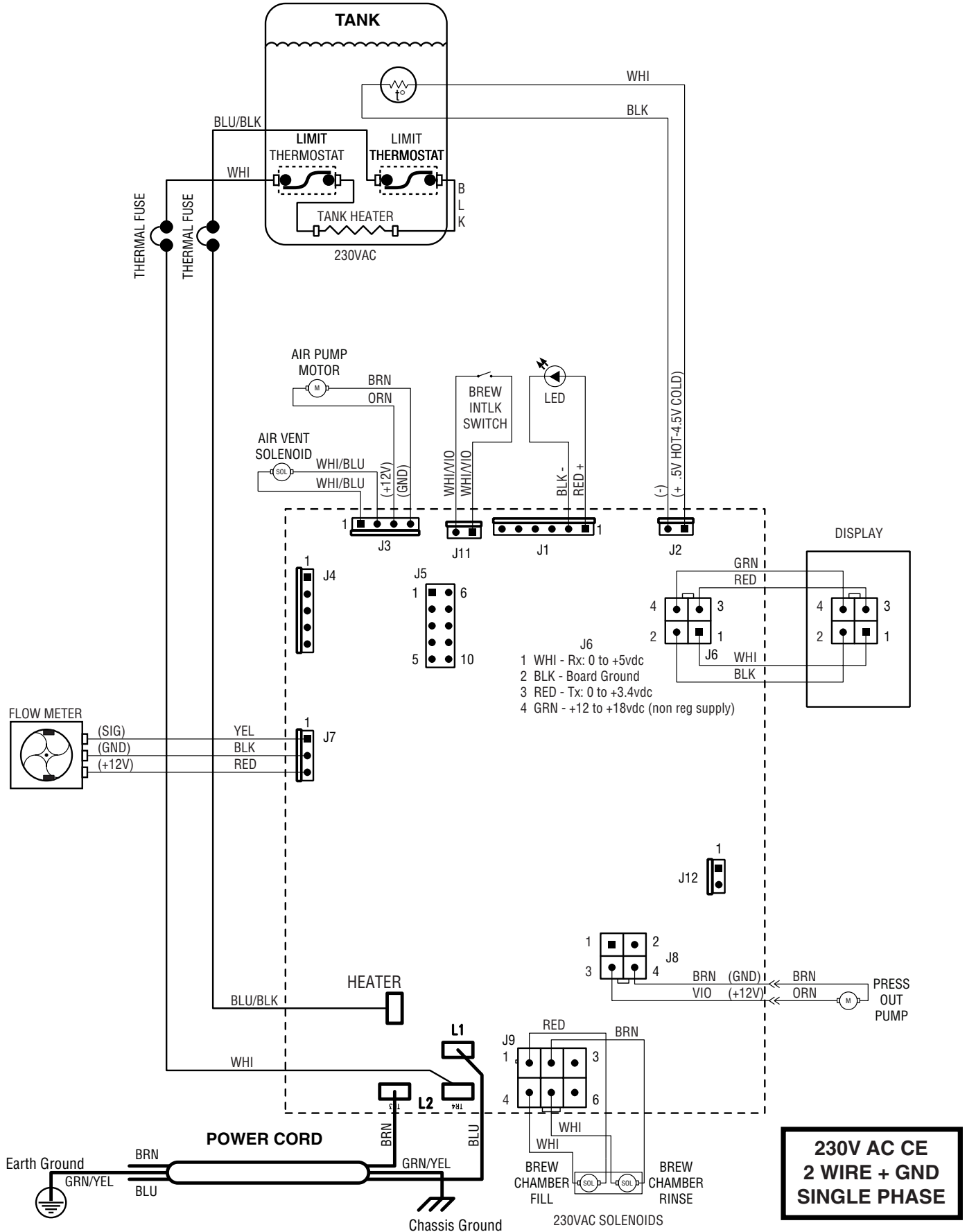

FIG. 17-1 TESTING TEMPERATURE PROBE

SCHEMATIC WIRING DIAGRAM TRIFECTA



SCHEMATIC WIRING DIAGRAM TRIFECTA



**230V AC CE
2 WIRE + GND
SINGLE PHASE**