

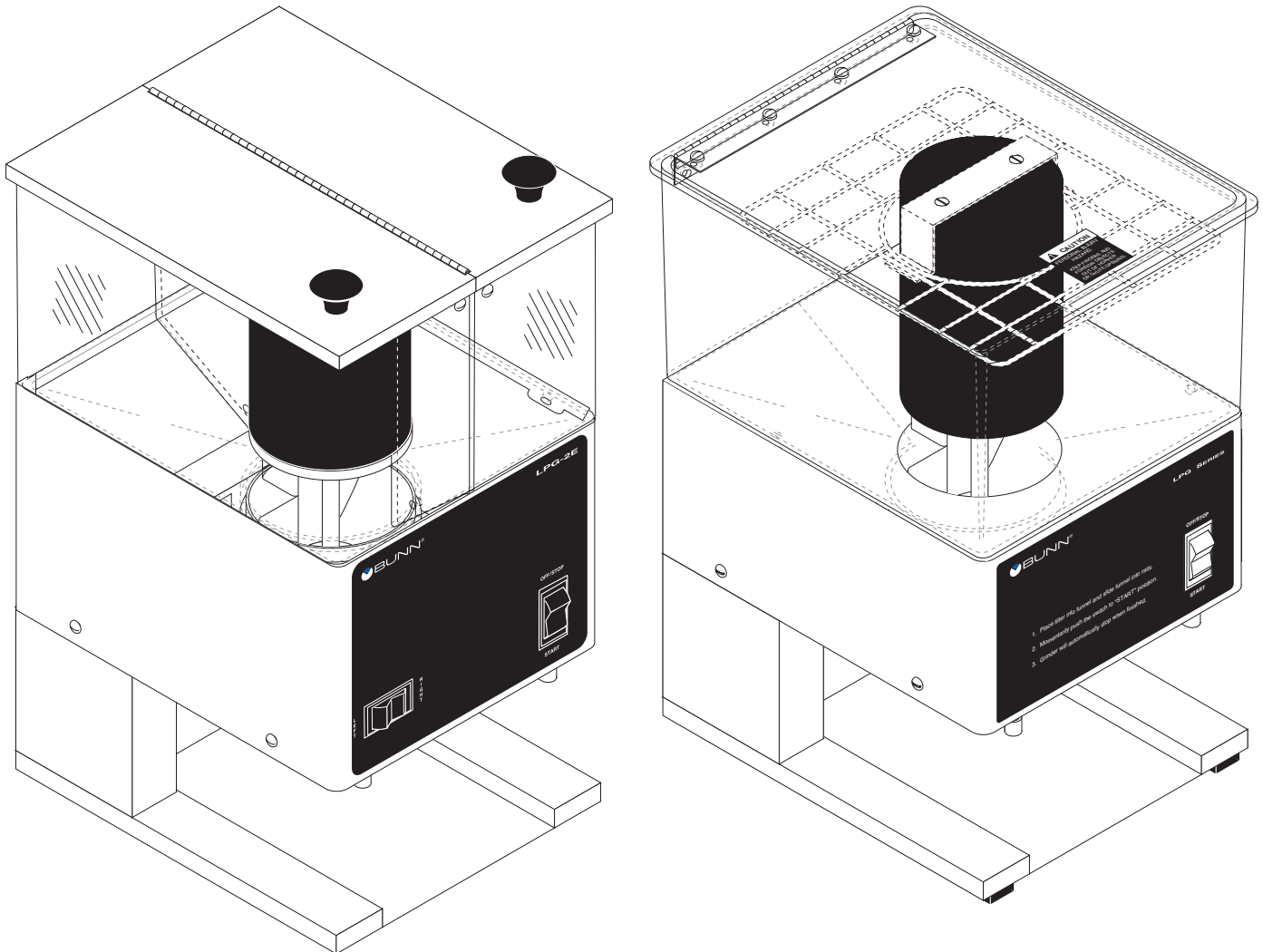

# LPG

# LPG-2E



## INSTALLATION & OPERATING GUIDE

### BUNN-O-MATIC CORPORATION

POST OFFICE BOX 3227

SPRINGFIELD, ILLINOIS 62708-3227

PHONE: (217) 529-6601 FAX: (217) 529-6644

[www.bunn.com](http://www.bunn.com)

To ensure you have the latest revision of the Operating Manual, or to view the Illustrated Parts Catalog, Programming Manual, or Service Manual, please visit the Bunn-O-Matic website, at [www.bunn.com](http://www.bunn.com). This is absolutely FREE, and the quickest way to obtain the latest catalog and manual updates. For Technical Service, contact Bunn-O-Matic Corporation at 1-800-286-6070.

## BUNN-O-MATIC COMMERCIAL PRODUCT WARRANTY

Bunn-O-Matic Corp. ("BUNN") warrants equipment manufactured by it as follows:

- 1) Airpots, thermal carafes, decanters, GPR servers, iced tea/coffee dispensers, MCP/MCA pod brewers thermal servers and Thermofresh servers (mechanical and digital)- 1 year parts and 1 year labor.
- 2) All other equipment - 2 years parts and 1 year labor plus added warranties as specified below:
  - a) Electronic circuit and/or control boards - parts and labor for 3 years.
  - b) Compressors on refrigeration equipment - 5 years parts and 1 year labor.
  - c) Grinding burrs on coffee grinding equipment to grind coffee to meet original factory screen sieve analysis - parts and labor for 4 years or 40,000 pounds of coffee, whichever comes first.

These warranty periods run from the date of installation BUNN warrants that the equipment manufactured by it will be commercially free of defects in material and workmanship existing at the time of manufacture and appearing within the applicable warranty period. This warranty does not apply to any equipment, component or part that was not manufactured by BUNN or that, in BUNN's judgment, has been affected by misuse, neglect, alteration, improper installation or operation, improper maintenance or repair, non periodic cleaning and descaling, equipment failures related to poor water quality, damage or casualty. In addition, the warranty does not apply to replacement of items subject to normal use including but not limited to user replaceable parts such as seals and gaskets. This warranty is conditioned on the Buyer 1) giving BUNN prompt notice of any claim to be made under this warranty by telephone at (217) 529-6601 or by writing to Post Office Box 3227, Springfield, Illinois 62708-3227; 2) if requested by BUNN, shipping the defective equipment prepaid to an authorized BUNN service location; and 3) receiving prior authorization from BUNN that the defective equipment is under warranty.

**THE FOREGOING WARRANTY IS EXCLUSIVE AND IS IN LIEU OF ANY OTHER WARRANTY, WRITTEN OR ORAL, EXPRESS OR IMPLIED, INCLUDING, BUT NOT LIMITED TO, ANY IMPLIED WARRANTY OF EITHER MERCHANTABILITY OR FITNESS FOR A PARTICULAR PURPOSE.** The agents, dealers or employees of BUNN are not authorized to make modifications to this warranty or to make additional warranties that are binding on BUNN. Accordingly, statements by such individuals, whether oral or written, do not constitute warranties and should not be relied upon.

If BUNN determines in its sole discretion that the equipment does not conform to the warranty, BUNN, at its exclusive option while the equipment is under warranty, shall either 1) provide at no charge replacement parts and/or labor (during the applicable parts and labor warranty periods specified above) to repair the defective components, provided that this repair is done by a BUNN Authorized Service Representative; or 2) shall replace the equipment or refund the purchase price for the equipment.

**THE BUYER'S REMEDY AGAINST BUNN FOR THE BREACH OF ANY OBLIGATION ARISING OUT OF THE SALE OF THIS EQUIPMENT, WHETHER DERIVED FROM WARRANTY OR OTHERWISE, SHALL BE LIMITED, AT BUNN'S SOLE OPTION AS SPECIFIED HEREIN, TO REPAIR, REPLACEMENT OR REFUND.**

In no event shall BUNN be liable for any other damage or loss, including, but not limited to, lost profits, lost sales, loss of use of equipment, claims of Buyer's customers, cost of capital, cost of down time, cost of substitute equipment, facilities or services, or any other special, incidental or consequential damages.

392, AutoPOD, AXIOM, BrewLOGIC, BrewMETER, Brew Better Not Bitter, BrewWISE, BrewWIZARD, BUNN Espresso, BUNN Family Gourmet, BUNN Gourmet, BUNN Pour-O-Matic, BUNN, BUNN with the stylized red line, BUNNlink, Bunn-OMatic, Bunn-O-Matic, BUNNserve, BUNNSERVE with the stylized wrench design, Cool Froth, DBC, Dr. Brew stylized Dr. design, Dual, Easy Pour, EasyClear, EasyGard, FlavorGard, Gourmet Ice, Gourmet Juice, High Intensity, iMIX, Infusion Series, Intellisteam, My Café, Phase Brew, PowerLogic, Quality Beverage Equipment Worldwide, Respect Earth, Respect Earth with the stylized leaf and coffee cherry design, Safety-Fresh, savemycoffee.com, Scale-Pro, Silver Series, Single, Smart Funnel, Smart Hopper, SmartWAVE, Soft Heat, SplashGard, The Mark of Quality in Beverage Equipment Worldwide, ThermoFresh, Titan, trifecta, Velocity Brew, A Partner You Can Count On, Air Brew, Air Infusion, Beverage Bar Creator, Beverage Profit Calculator, Brew better, not bitter., BUNNSource, Coffee At Its Best, Cyclonic Heating System, Daypart, Digital Brewer Control, Nothing Brews Like a BUNN, Pouring Profits, Signature Series, Tea At Its Best, The Horizontal Red Line, Ultra are either trademarks or registered trademarks of Bunn-O-Matic Corporation.

## CONTENTS

User Notices .....	3
Electrical Requirements .....	4
Preventive Maintenance .....	4
Operating Controls.....	4
Cleaning .....	5
Coffee Grinding .....	5
Initial Set-Up .....	6
Adjustments.....	6

## INTRODUCTION

The LPG will store up to six pounds and the LPG-2E will store up to three pounds of whole bean coffee in each of two hoppers and grind it to a preset grind and amount into an awaiting funnel and filter from most commercial drip coffee brewers. The equipment is only for indoor use on a sturdy counter or shelf. Adequate space must be available above the grinder to raise the lid when adding beans. Use only with whole bean coffee.

The grind is preset at the factory to drip specifications as set forth by the United States Department of Commerce and adopted by the Coffee Brewing Center of the Pan American Coffee Bureau. Adjustments may be made to alter both the amount and grind from the factory setting.

## USER NOTICES

Carefully read and follow all notices on the grinder and in this manual. They were written for your protection. All notices on the grinder are to be kept in good condition. Replace any unreadable or damaged labels.



#05876.0000

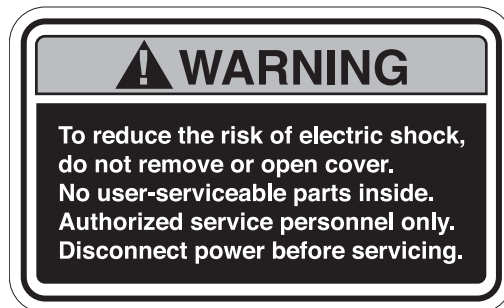

#37881.0000



#20545.0000



00824.0002

## ELECTRICAL REQUIREMENTS

The grinder has an attached cordset and requires 2-wire, grounded service rated 120 volts ac, 15 amp, single phase, 60 Hz for 120V models; and 100 volts ac, 15 amp single phase, 50Hz for 100V models.

## OPERATING CONTROLS

### Off/On/Start Switch (Models LPG and LPG-2E)

**OFF** - (upper position) Switching to this position stops all operation of the grinder.

**ON** - (middle position) The switch will return to this position after a grind cycle has begun and will remain in this position after grinding has ceased.

**START** - (lower, momentary position) Pressing the switch to this position and releasing initiates a grind cycle.

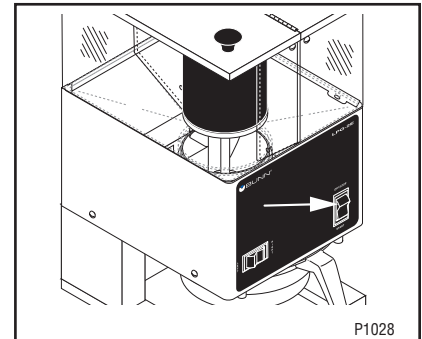

### Hopper Selector Switch (Model LPG-2E only)

**LEFT** - Switching to this position allows beans to be ground from the left hopper.

**RIGHT** - Switching to this position allows beans to be ground from the right hopper.

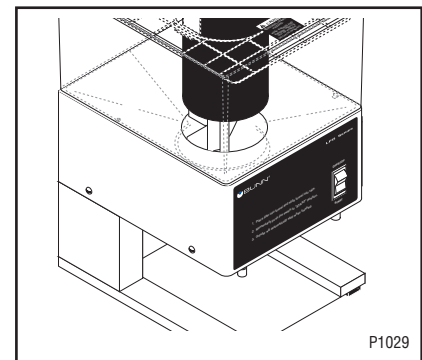

## PREVENTIVE MAINTENANCE

Bunn-O-Matic® Corporation recommends that preventive maintenance be performed at regular intervals. Maintenance should be performed by a qualified service technician. For Technical Service, contact Bunn-O-Matic® Corporation at 1-800-286-6070.

**NOTE: Replacement parts or service caused by failure to perform required maintenance is not covered by warranty.**

### 6-Month

Weekly Cleaning plus replace the dechaffer assembly.

### 1-Year

1. On grinders with slide plates check the slide plates and clean.
2. Inspect and clean/replace burrs and grind chamber if necessary.
3. Adjust the burrs and grind time to your specifications for particulate size and throw weight.

## CLEANING

### EXTERIOR SURFACES

The use of a damp cloth rinsed in any mild, nonabrasive, liquid detergent is recommended for cleaning all surfaces on Bunn-O-Matic equipment. Care should be taken not to scratch the hopper or windows with any abrasive material. Regular cleaning will keep your grinder looking new for years.

### GRIND CHAMBER

1. **WARNING** - Unplug grinder before removal of any panel or grind chamber housing parts.
2. Empty all beans from both hopper(s).
3. Plug-in the grinder, place funnel with filter into funnel rails. Press the Off/On/Start switch to the "START" lower position and release. Run a few grind cycles until all the coffee in the grind chamber is dispensed and disconnect grinder from the power source.
4. Remove the funnel with filter and carefully tip the grinder over on it's back.
5. Remove the two #10-32 screws securing burr housing cap assembly to the burr housing and remove burr housing cap assembly.
6. Remove load disc and slide rotor with lower burr, spring and brass bushing off of the motor shaft.
7. Clean the grind chamber and all parts with a dry non metallic bristle brush and wipe with a dry clean cloth.
8. Reinstall brass bushing (flanged end first), spring and rotor with lower burr onto the motor shaft. Reinstall load disc flat side toward rotor and burr housing cap assembly to the burr housing.
9. Refer to Initial Set-up/Adjustments section to vary grind or weight of dispensed coffee if necessary.

### COFFEE GRINDING

1. On models LPG-2E, select (either left or right hopper) with selector switch and visually inspect the desired hopper for an ample supply of whole bean coffee.
2. Place a paper filter into the brew funnel. The filter must not be folded-over or tilted to one side.
3. Insert the funnel into the funnel rails and push until it stops.
4. Momentarily press Off/On/Start switch to the "START" lower position and release. The grinding action will stop automatically after the preset amount of ground coffee is dispensed into the funnel.
5. Remove the funnel from the grinder and level the bed of grounds by gently shaking.
6. The loaded funnel is now ready for use in any commercial drip coffee brewer according to the manufacturer's instructions.

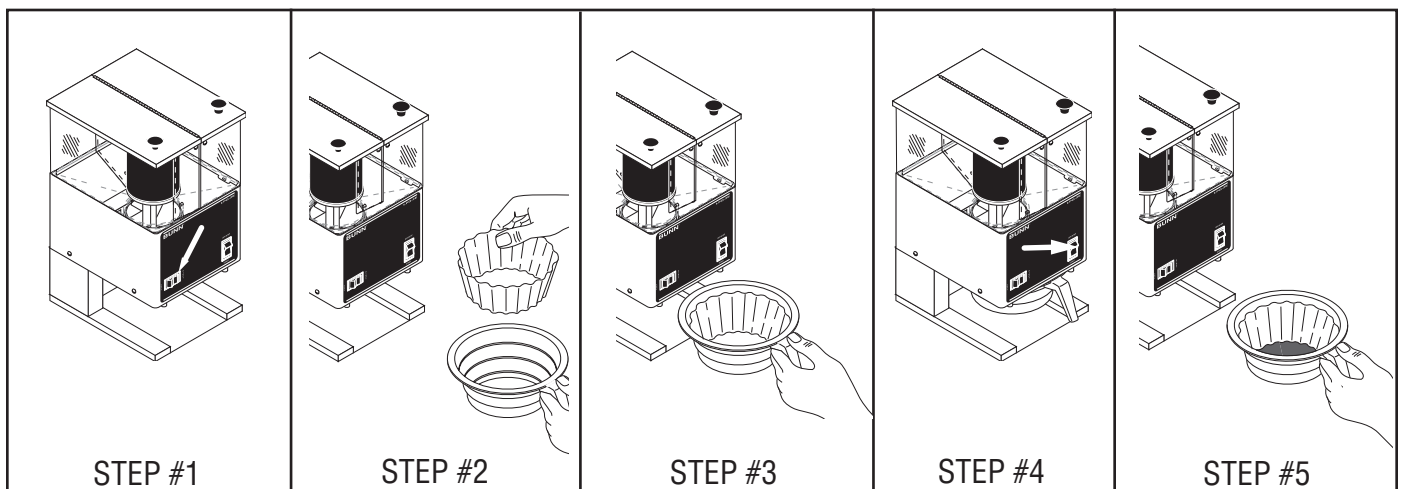

## INITIAL SET-UP/ADJUSTMENTS

The grind can be set from fine to very coarse. The grind may be adjusted for use in most commercial coffee brewers. The following procedures should be used to make adjustments.

**NOTE** - A change in the burr adjustment will also change the amount dispensed. Any adjustment to the burrs should be followed by an adjustment of the timer dials.

### Burr Adjustment

1. Unplug the grinder and empty all beans from the hopper(s).
2. Plug-in the grinder, place funnel with filter into the funnel rails. Momentarily press the Off/On/Start switch to the "START" (lower) position (with desired hopper selected) and release, run a few grind cycles until all of the coffee in the grind chamber is dispensed.
3. Remove the funnel with filter and carefully tip the grinder over on it's back.
4. Place the Off/On/Start switch in the "START" (lower) position and, using the grind adjustment key provided, slowly turn the adjusting screw in a clockwise direction until a metallic whine is heard due to the rubbing of the grinding burrs. (It may be necessary to start more than one grind cycle to obtain the sound).
5. Make a mark with a pen on the decal to note the position of the arrow on the grind adjustment screw.
6. The following settings approximately correspond to the CBC recognized grinds. All are referenced from the arrow position marked in step #5.

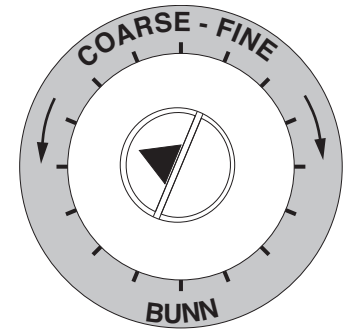

P1073

**FINE GRIND:** Rotate the adjusting screw 7 hash marks in a counterclockwise direction.

**DRIP GRIND:** Rotate the adjusting screw 8 hash marks in a counterclockwise direction.

**REGULAR (COARSE) GRIND:** Rotate the adjusting screw 10 hash marks in a counterclockwise direction.

NOTE: Exact adjustment will vary according to bean roast or added flavoring.

### Timer Adjustment (Model LPG-2E)

1. Fill hoppers with whole bean coffee and select hopper to be adjusted.
2. Remove the cover from the timer dials.
3. Set the timer dial to 2 seconds for each 1-1/2 ounces of ground coffee desired.
4. Grind a few cycles to verify the setting by weighing samples.
5. Adjust the timer to correspond with the chart below.

#### Approximate Amount (in Ounces)      Timer Settings (in Seconds)

1-1/2	2
2-1/4	3
3	4

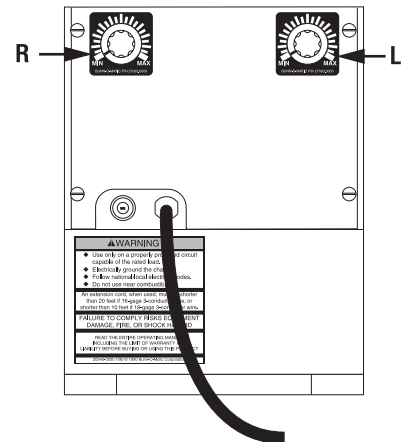

P1035

6. Repeat steps 2 - 4 for remaining hopper.

### Timer Adjustment (Model LPG)

1. Unplug the grinder and remove the 2" hole plug in the rear cover.
2. Set the timer dial to 5 seconds for each ounce of ground coffee desired.
3. Verify the setting by weighing a few samples.

**Use this 5 second per ounce figure as an APPROXIMATE guide only.**

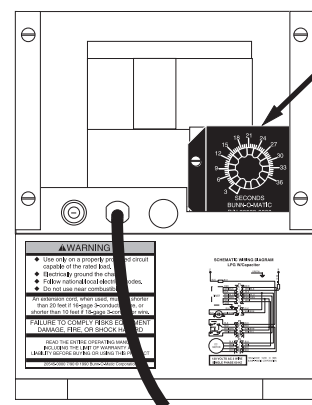

P1744

27091 081313