

CWTF15-3, PF (2U/1L Warmer)

Height: 19.0" (48.3cm) Width: 8.4" (21.3cm) Depth: 21.4" (54.4cm)



- Model is space-saving 8.5" (21.6cm) wide
- All stainless steel construction
- Hot water faucet (requires active plumbing connection)
- Pourover feature
- SplashGard® funnel deflects hot liquids away from the hand
- PROP 65 Warning Decal included in packaging with equipment
- Servers not included unless otherwise noted

Server(s) sold separately

Agency:



Specifications

Product #: 12950.0213

Faucet: Upper

Water Access: Plumbed

Warmers: Two Upper/ One Lower

Finish: Stainless

Funnel: Black Plastic

Additional Features

Pourover Option

Electrical & Capacity

Volts*	Amps	Watts	Cord Attached	Plug Type	8oz cups/hr 236ml cups/hr	Input H ² O Temp.	Phase	# Wires plus Ground	Hertz
120	13.9	1670	Yes	NEMA 5-15P	61	60°F (15.5°C)	1	2	60

*When a BUNN is machine rated 120/208-240V, 120/208V or 120/240V, the higher voltage is the supply voltage needed to power the machine. The 120V is there to supply power to some components rated 120V in the machine, but it is not the supply voltage and would not power the machine if the machine is marked with the before mentioned ratings.

Plumbing Requirements

PSI	kPa	Fitting Supplied	Water Flow Required (GPM)
20-90	138-621	1/4" Male Flare Fitting	-

CAD Drawings

2D	Revit	KLC
●		

WARNING: This product can expose you to chemicals including Bisphenol A (BPA), which is known to the State of California to cause birth defects or other reproductive harm. For more information go to www.P65Warnings.ca.gov



BUNN® reserves the right to change specifications and product design without notice. Such revisions do not entitle the buyer to corresponding changes, improvements, additions or replacements for previously purchased equipment. For most current specifications and other info visit bunn.com.

Last Updated:
03/25/2026

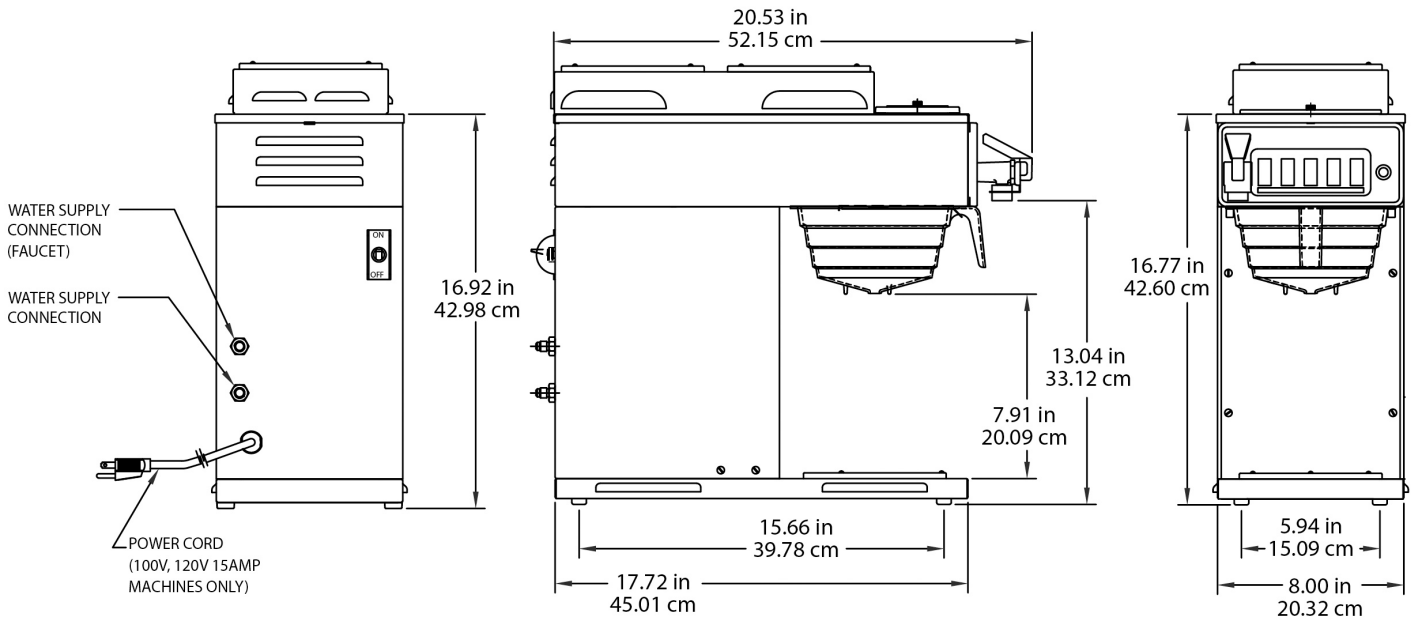
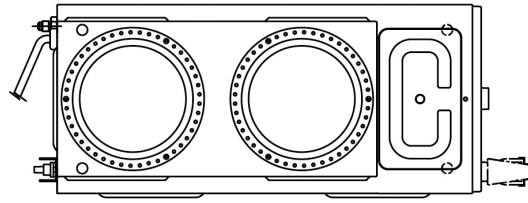

	Unit			Shipping				
	Height	Width	Depth	Height	Width	Depth	Weight	Volume
English	19.0 in.	8.4 in.	21.4 in.	23.8 in.	12.5 in.	26.5 in.	33.050 lbs	4.566 ft ³
Metric	48.3 cm	21.3 cm	54.4 cm	60.3 cm	31.8 cm	67.4 cm	14.991 kgs	0.129 m ³



BUNN® reserves the right to change specifications and product design without notice. Such revisions do not entitle the buyer to corresponding changes, improvements, additions or replacements for previously purchased equipment. For most current specifications and other info visit bunn.com.

Last Updated:
03/25/2026

Related Products & Accessories: CWTF15-3, PF (2U/1L Warmer)(12950.0213)



FUNNEL W/DECAL, PPK
NAR BLK (SM)

Product #: 02774.0011²



FUNNEL W/DECAL, PPK
NAR BLK (LG)

Product #: 04274.0012²



FILTERS, REGULAR 1M
500/2 50/CL

Product #: 20115.0000



FUNNEL ASSY, SST-BLK
HDL (7.12)

Product #: 20216.0000²



FUNNEL W/DECALS,
BLACK PLASTIC

Product #: 20583.0003²



FUNNEL ASSY, SST-PP
BLK HDL

Product #: 29151.0000²



FUNNEL ASSY, SST-PP
ORANGE HDL

Product #: 29151.0001²



WATER FILTER
SYSTEM, EQ-17-TL

Product #: 30200.1000³



WATER FILTER, IN LINE
ED-17-TL

Product #: 30201.1001³



SYSTEM, WEQ-10 (1.5) 5L

Product #: 56000.0024¹



CARTRIDGE, WEQ-10
(1.5) 5L

Product #: 56000.0121¹



CARTRIDGE, WEQ-10.3
(1.67) 5L

Product #: 56000.0137¹

¹NSF Certified ²NSF Certified with spec sheet model listed ³NSF Certified under Solventum Purification ⁴NSF Certified under Vivreau Ltd ⁵NSF Certified under Zojirushi ⁶NSF Certified under Qins Inc ⁷NSF COMPONENT Certified



BUNN® reserves the right to change specifications and product design without notice. Such revisions do not entitle the buyer to corresponding changes, improvements, additions or replacements for previously purchased equipment. For most current specifications and other info visit bunn.com.

Last Updated:
03/25/2026

Serving & Holding Options: CWTF15-3, PF (2U/1L Warmer)(12950.0213)

				
EASY POUR®,(BLK) 1/CS Product #: 06100.0101	EASY POUR®,(BLK) 2/CS Product #: 06100.0102	EASY POUR®,(BLK) 3/CS Product #: 06100.0103	EASY POUR®,(BLK) 6/CS Product #: 06100.0106	EASY POUR®,(BLK) 12/CS Product #: 06100.0112

				
EASY POUR®,(BLK) 24/CS Product #: 06100.0124	EASY POUR®,(ORN) 1/CS Product #: 06101.0101	EASY POUR®,(ORN) 2/CS Product #: 06101.0102	EASY POUR®,(ORN) 3/CS Product #: 06101.0103	EASY POUR®,(ORN) 24/CS Product #: 06101.0124

				
DECANTER, GLASS-BLK 12C 24/CS Product #: 42400.0024	DECANTER, GLASS-BLK 12CUP 1PK Product #: 42400.0101	DECANTER, GLASS-BLK 12C 3/CS Product #: 42400.0103	DECANTER, GLASS-ORN 12C 24/CS Product #: 42401.0024	DECANTER, GLASS-ORN 12 CUP 1PK Product #: 42401.0101

¹NSF Certified ²NSF Certified with spec sheet model listed ³NSF Certified under Solventum Purification ⁴NSF Certified under Vivreau Ltd ⁵NSF Certified under Zojirushi ⁶NSF Certified under Qins Inc ⁷NSF COMPONENT Certified



BUNN® reserves the right to change specifications and product design without notice. Such revisions do not entitle the buyer to corresponding changes, improvements, additions or replacements for previously purchased equipment. For most current specifications and other info visit bunn.com.

Last Updated:
03/25/2026

Serving & Holding Options: CWTF15-3, PF (2U/1L Warmer)(12950.0213)



DECANTER, GLASS-ORN
12C 3/CS

Product #: 42401.0103



BUNN® reserves the right to change specifications and product design without notice. Such revisions do not entitle the buyer to corresponding changes, improvements, additions or replacements for previously purchased equipment. For most current specifications and other info visit bunn.com.

Last Updated:
03/25/2026